

Chicago Valves & Controls

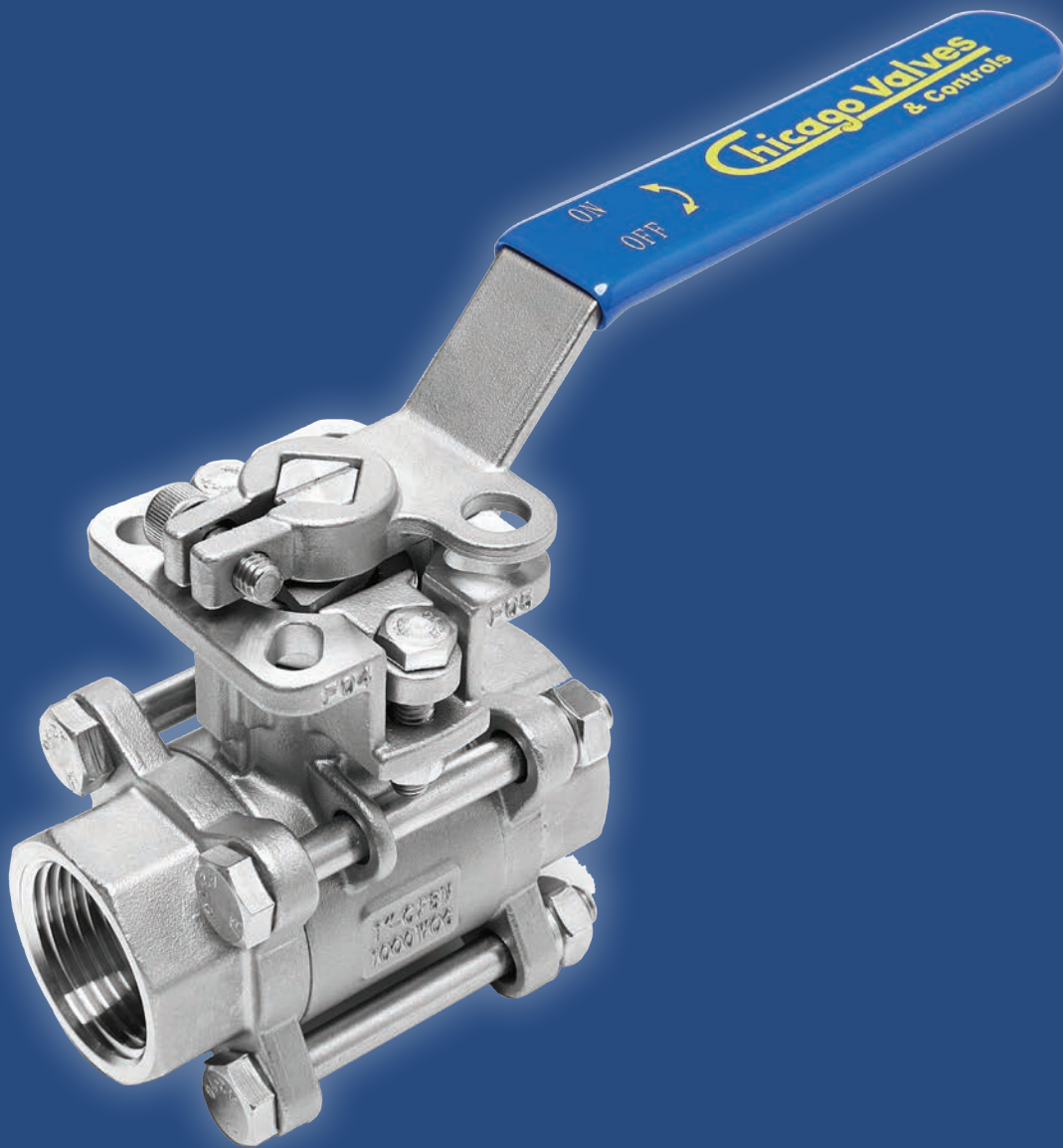

SERIES 35
DIRECT MOUNTED 3PC
FULL PORT BALL VALVE

1000 CWP (1/4"-2")
800 CWP (2 1/2"-4")
316 STAINLESS STEEL - ASTM A351
CARBON STEEL - ASTM A216 WCB
HIGH CYCLE LIVE LOADED STEM PACKING
ANTI STATIC DEVICE
STEAM RATING 150 PSI WSP
VACUUM SERVICE TO 29" Hg
DIRECT MOUNTED
ELEVATED MOUNTING PAD ALLOWING TO ADJUST GLAND PACKING FLANGE WHILE THE VALVE IN SERVICE WITHOUT REMOVING THE ACTUATOR
ANTI-STATIC DESIGN

Series 35

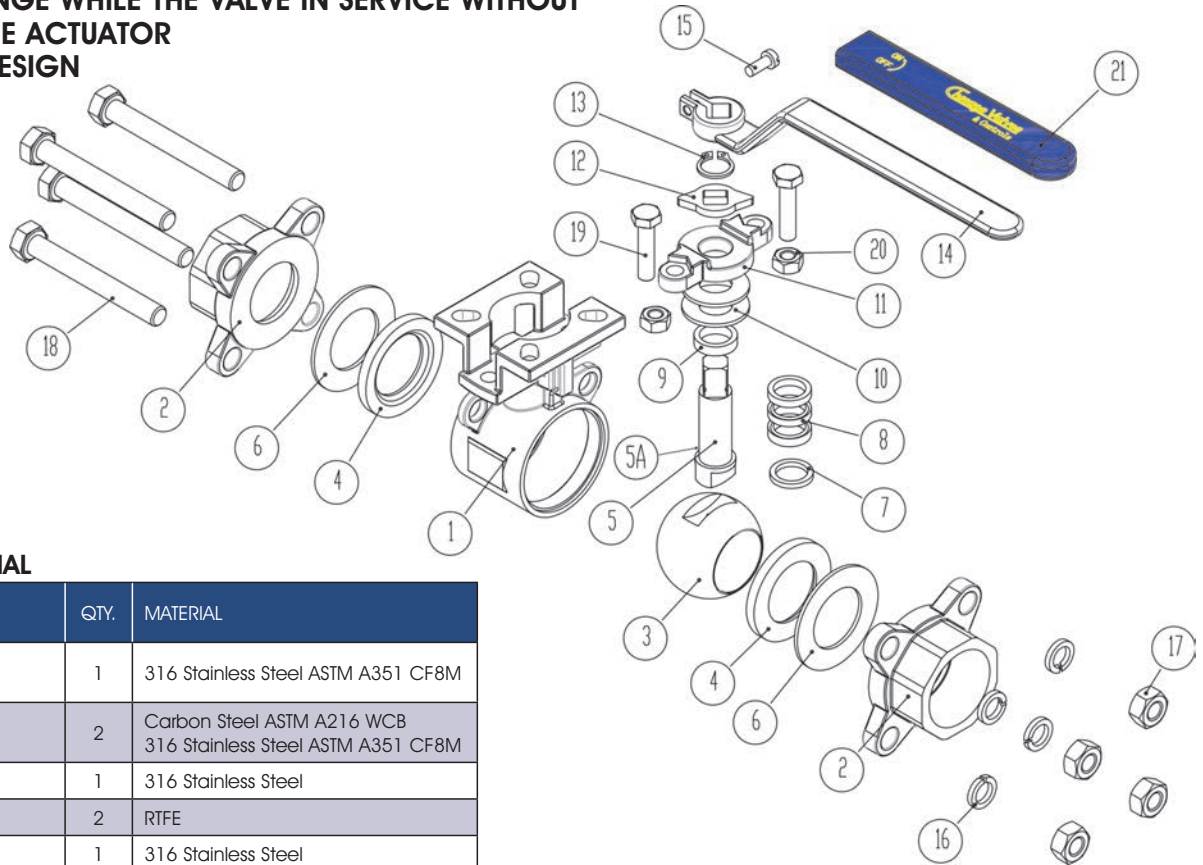

PARTS & MATERIAL

PART NO.	PART NAME	QTY.	MATERIAL
1	Body	1	316 Stainless Steel ASTM A351 CF8M
2	End Cap	2	Carbon Steel ASTM A216 WCB 316 Stainless Steel ASTM A351 CF8M
3	Ball	1	316 Stainless Steel
4	Seat	2	RTFE
5	Stem	1	316 Stainless Steel
5A	Anti-Static Ball 2 1/2"-4"	2	300 Series Stainless Steel Hard Drawn Stainless Steel
6	Body Seal	2	PTFE
7	Thrust Washer	1	Carbon Fill PTFE
8	Stem Packing	3	PTFE
9	Gland Packing	1	304 Stainless Steel
10	Belleville Washer	2	300 Series Stainless Steel
11	Gland Flange	1	304 Stainless Steel
12	Travel Stopper	1	304 Stainless Steel
13	Snap Ring	1	300 Series Stainless Steel
14	Handle	1	304 Stainless Steel
15	Bolt	1	300 Series Stainless Steel
16	Spring Washer	1	300 Series Stainless Steel
17	Nut	4	300 Series Stainless Steel
18	Body Bolts	4/6	300 Series Stainless Steel
19	Gland Bolts	2	300 Series Stainless Steel
20	Nut	2	300 Series Stainless Steel
21	Handle Sleeve	2	PVC

Series 35

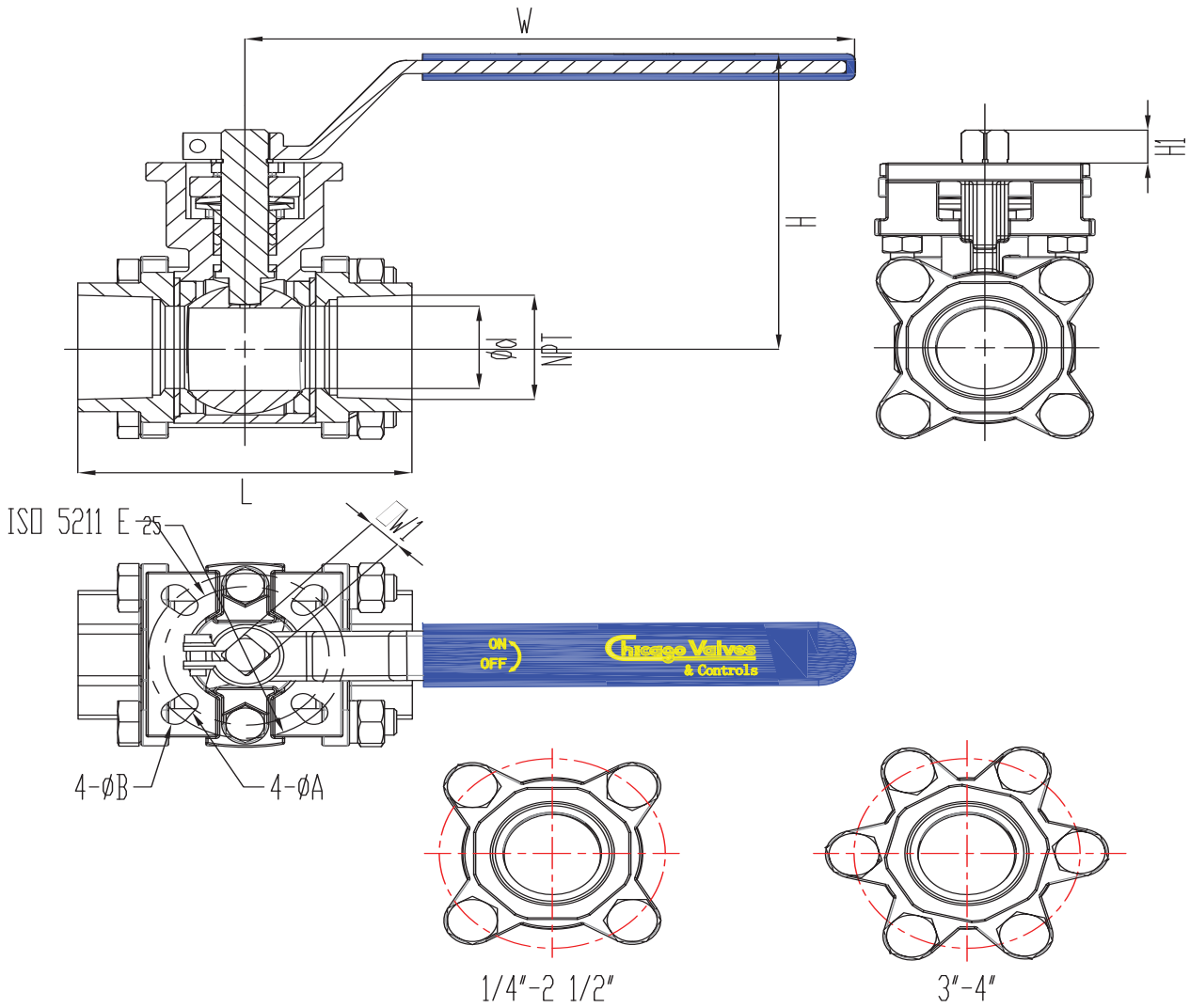

DIMENSIONS (INCHES)

SIZE	d	L	H	W	ISO 5211	E	H1	W1	A	B
1/4"	0.46	2.28	2.91	4.84	F03-F04	1.42-1.65	0.39	0.35	0.24	0.24
3/8"	0.50	2.28	2.91	4.84	F03-F04	1.42-1.65	0.39	0.35	0.24	0.24
1/2"	0.59	2.48	2.91	4.84	F03-F04	1.42-1.65	0.39	0.35	0.24	0.24
3/4"	0.79	2.87	3.07	4.84	F03-F04	1.42-1.65	0.39	0.35	0.24	0.24
1"	0.98	3.35	3.50	6.02	F04-F05	1.65-1.97	0.47	0.43	0.24	0.28
1 1/4"	1.26	3.78	3.70	6.02	F04-F05	1.65-1.97	0.47	0.43	0.24	0.28
1 1/2"	1.50	4.49	4.33	7.28	F05-F07	1.97-2.76	0.63	0.55	0.28	0.35
2"	1.97	5.28	4.65	7.28	F05-F07	1.97-2.76	0.63	0.55	0.28	0.35
2 1/2"	2.56	6.34	6.34	13.86	F07-F10	2.76-4.02	0.75	0.67	0.35	0.43
3"	3.15	7.76	6.69	13.86	F07-F10	2.76-4.02	0.75	0.67	0.35	0.43
4"	3.94	8.98	7.95	15.63	F10-F12	4.02-4.92	0.94	0.87	0.43	0.51

APPLICABLE STANDARDS

SHELL AND SEAT PRESSURE TESTS	ASME B16.34
THREADED AND SOCKET WELD ENDS	ASME B16.11
BUTT WELD ENDS	ASME B16.25
MOUNTING PAD	ISO 5211

SIZE	CV (GPM)	WEIGHT (LBS)
1/4"	6	1.63
3/8"	7	1.61
1/2"	10	1.54
3/4"	25	1.79
1"	35	1.24
1 1/4"	46	2.73
1 1/2"	80	6.37
2"	110	8.49
2 1/2"	310	17.97
3"	360	28.33
4"	820	46.96

PRESSURE-TEMPERATURE RATING 1/4"-4" SERIES 35

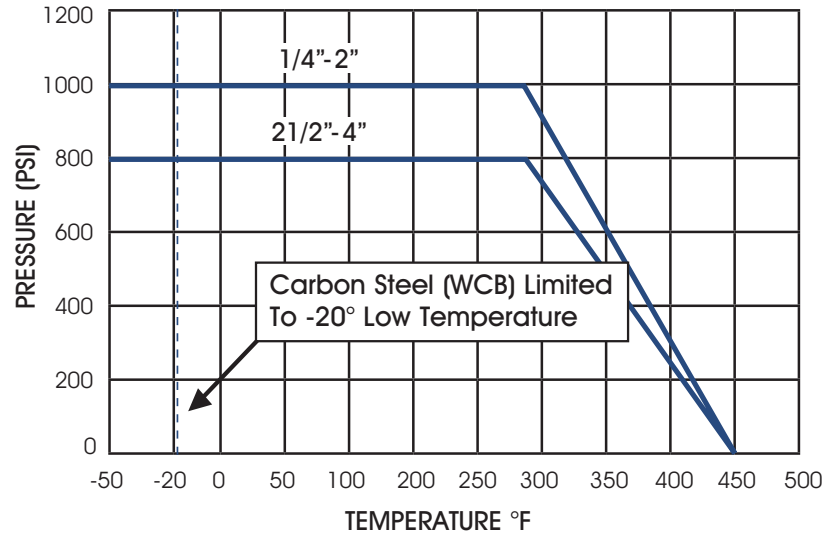

HOW TO ORDER

SIZE	SERIES	BODY	BALL & STEM	SEATS	ENDS	ENDS	OPERATOR
1"	35	6 316 Stainless Steel	6 316 Stainless Steel	R RTFE	6 316 Stainless Steel 4 Carbon Steel	TE Threaded Ends SW Socket Weld Ends T/S Threaded / Socket Weld BW4 Butt Weld SCH 40 BW1* Butt Weld SCH 10	1 Bare Stem 2 Lockable Handle

*6-316 Stainless Steel

Chicago Valves & Controls



Toll-Free (833) 831-2312

Local (312) 637-3557

Fax: (312) 637-3543

E-Mail: sales@chicagovalves.com

www.chicagovalves.com

885 Cambridge Dr.

Elk Grove Village, Illinois 60007 U.S.A.